



Important

- Please inspect this product immediately on delivery to ensure that it has not been damaged in transit and is complete. Any claim for damage or shortage will not be entertained unless received within 3 days.
- To ensure this product is installed properly, you must read and follow these guidelines.
- Please read the whole of these instructions before starting installation.
- Be sure your installation conforms to local regulations.
- We recommend that this product is installed by a qualified professional contractor.
- Please refer to the specification and assembly drawings attached.
- Before installation, please inspect this product to ensure that it is the correct model and you have all the parts required for proper installation.
- Take all the necessary precautions to ensure that all parts are properly protected during installation. Polished and plated surfaces are particularly prone to damage from dirty and incorrect tools; spanners should be suitably lined so as not to damage plated or polished nuts.

Flush the existing system with water to ensure that there is no debris in the existing pipework before commencing installation.

When drilling holes in walls or floors be aware of any existing pipes or cables.

Where the water pressure is more than 3 bar we recommend a pressure reducing valve is fitted.

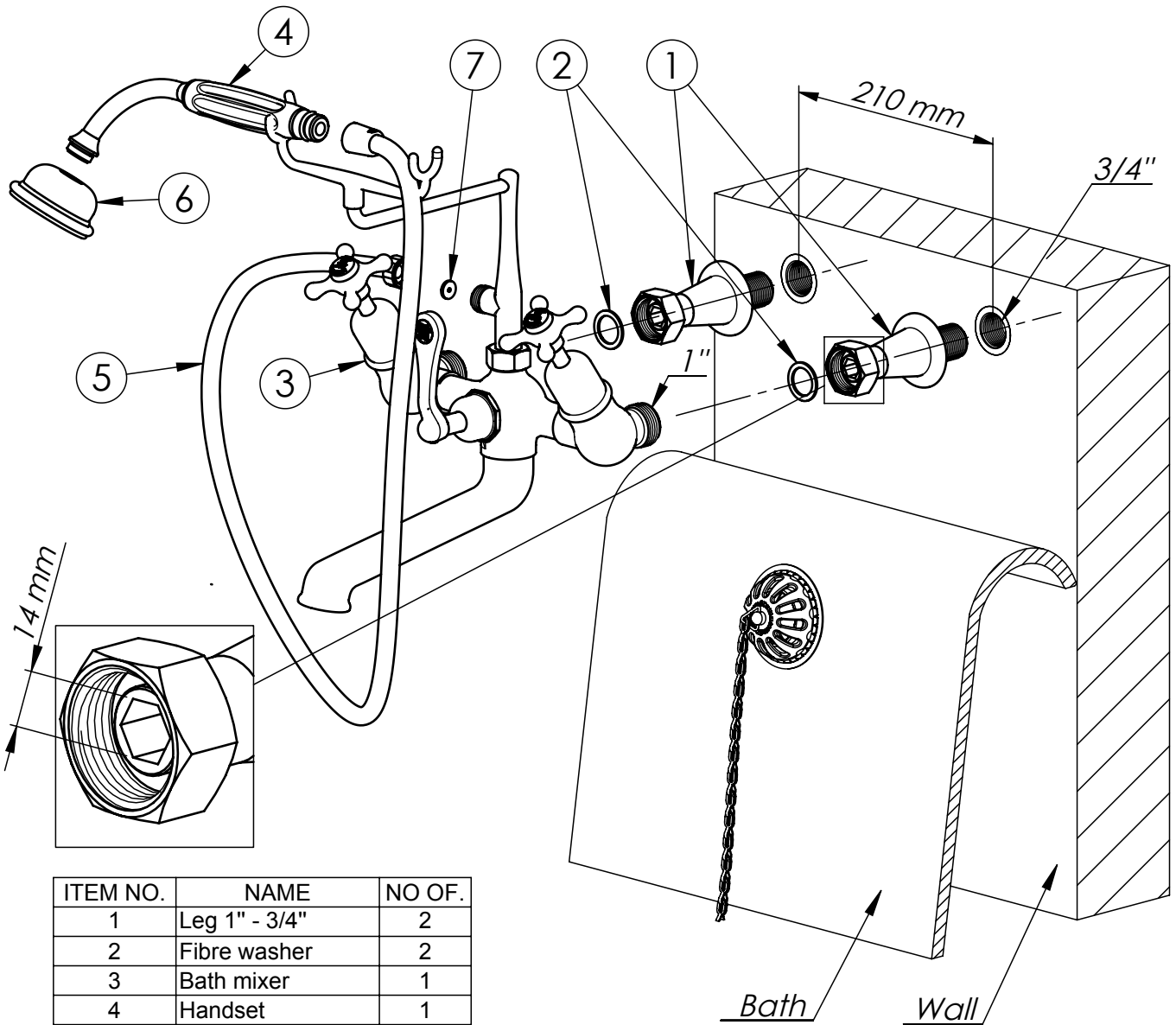

ITEM NO.	NAME	NO OF.
1	Leg 1" - 3/4"	2
2	Fibre washer	2
3	Bath mixer	1
4	Handset	1
5	Shower hose	1
6	Shower rose	1
7	Reduction washer	1

Installation

1. Check that all the parts required are present
2. This mixer requires that the supply terminates in fixed 22mm (¾") BSP female coupling at 210mm centres. It is, however possible to use a 22mm backnut (not supplied) to secure the legs if they reach through a backplate and the supply can then terminate in a 22mm swivel or flexible coupling.
3. Check that the supply is at 210mm centres.
4. Flush the water system to ensure that no swarf can enter the mixer taps.
5. Smear or wind a suitable sealing material round the threads of the legs (1) and screw them into the supply using a 14mm allen key. Note that a fibre washer (not supplied) may be inserted between the leg and the wall or tile surface to protect it.
6. Fit the fibre washers (2) over the upstand in the legs and fit the complete bath mixer (3) to the legs, making sure that the upstand in the legs engages the tap body correctly. Tighten using a clean flat properly fitting open spanner fitted with nylon or copper faced jaws to avoid damaging the plating.
7. Fit the shower hose (5) to the handset (4), fit the shower rose (6) to the handset (4), attach shower hose (5) to the bath mixer (3) making sure that the pressure reduction washer (7) is inserted, do not tighten these fittings more than hand tight.
8. Clean any excess sealant from the fittings.
9. Test and check that all joints are watertight.

Notes: Drummond's products are handmade therefore dimensions may vary slightly.
 Please try to recycle all packaging where possible and leave the item well protected for the customer - thank you.
 The manufacturer's warranty does not cover any products which have been damaged as a result of misuse, faulty installation or maintenance.

Cleaning

Brass - use a mild non-abrasive cleaner such as brasso.
 Chrome and nickel plated products - use a mild non-abrasive cleaner such as silvo.

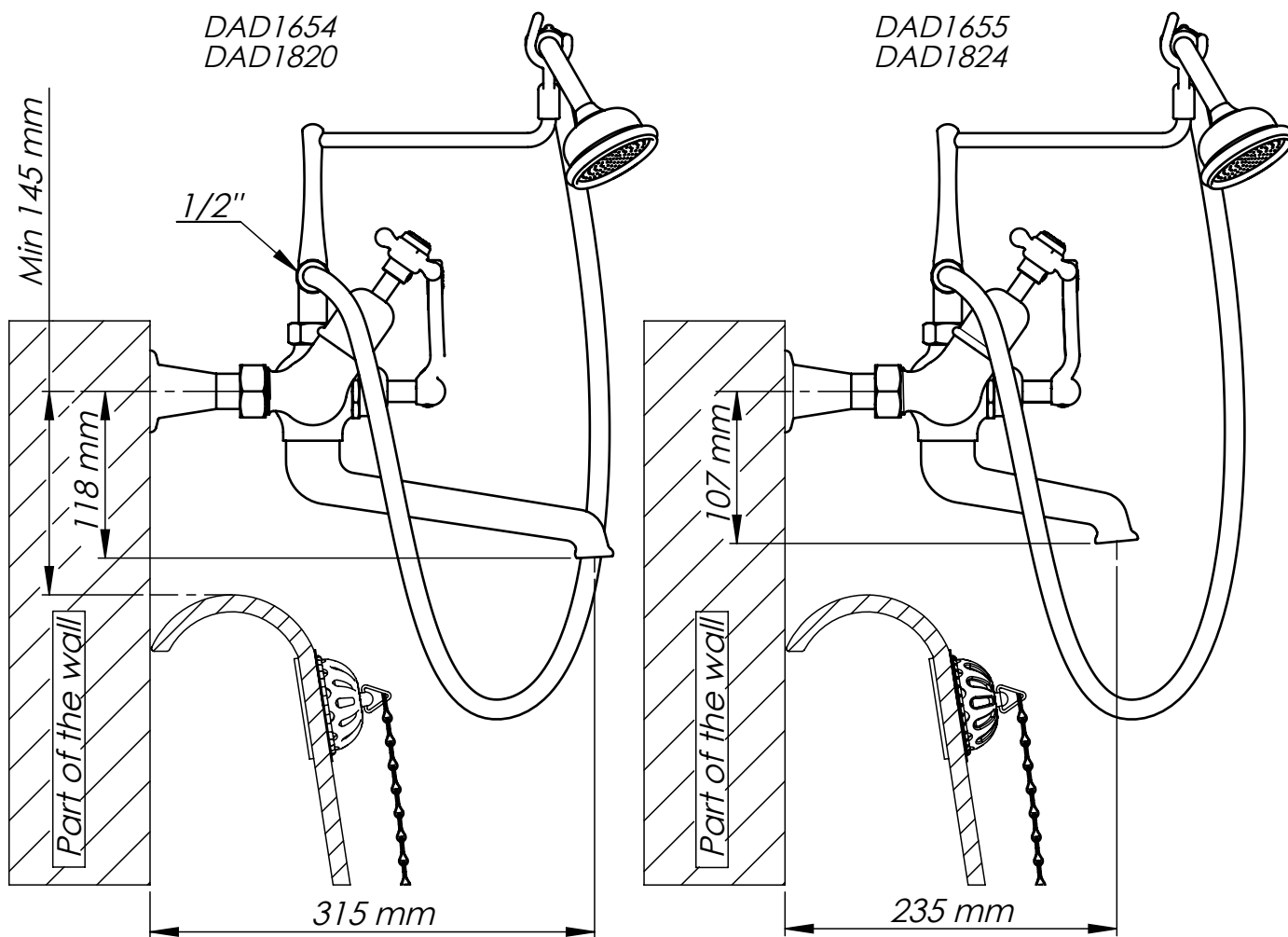

All our goods are handmade and may vary slightly from drawings. If you are unsure of how to assemble the goods, please call us and we will try help over the phone. We would also ask that you try and recycle all packing where possible and leave the item well protected for the customer. Thank you.