



Important

- Please inspect this product immediately on delivery to ensure that it has not been damaged in transit and is complete. Any claim for damage or shortage will not be entertained unless received within 3 days.
 - To ensure this product is installed properly, you must read and follow these guidelines.
 - Please read the whole of these instructions before starting installation.
 - Be sure your installation conforms to local regulations.
 - We recommend that this product is installed by a qualified professional contractor.
 - Please refer to the specification and assembly drawings attached.
 - Before installation, please inspect this product to ensure that it is the correct model and you have all the parts required for proper installation.
 - Take all the necessary precautions to ensure that all parts are properly protected during installation.
- Polished and plated surfaces are particularly prone to damage from dirty and incorrect tools; spanners should be suitably lined so as not to damage plated or polished nuts.

Water pressures must not exceed a 6:1 ratio and flow limiters should be fitted when the pressure difference is greater than 5:1. Hot water supply temperature must not exceed 80C, advised 60C - 65C.

Operating pressure must not exceed 5 Bar and where pressure is greater than 3 bar a pressure reducer should be fitted before the control block.

Filters on the supply pipes must be fitted to stop debris entering the control block valves.

Hot water feed should be on the left.

The temperature setting in the control block has been factory set, if adjustment is required ie if your installation exceeds greatly the factory setting of 65C hot water feed and balanced pressures, Drummonds should be contacted for instructions for altering the setting.

The supply requires that the feed terminates in 3/4" female fitting at 245mm centers.

Flush the existing system with water to ensure that there is no debris in the existing pipework before commencing installation.

When drilling holes in walls or floors be aware of any existing pipes or cables.

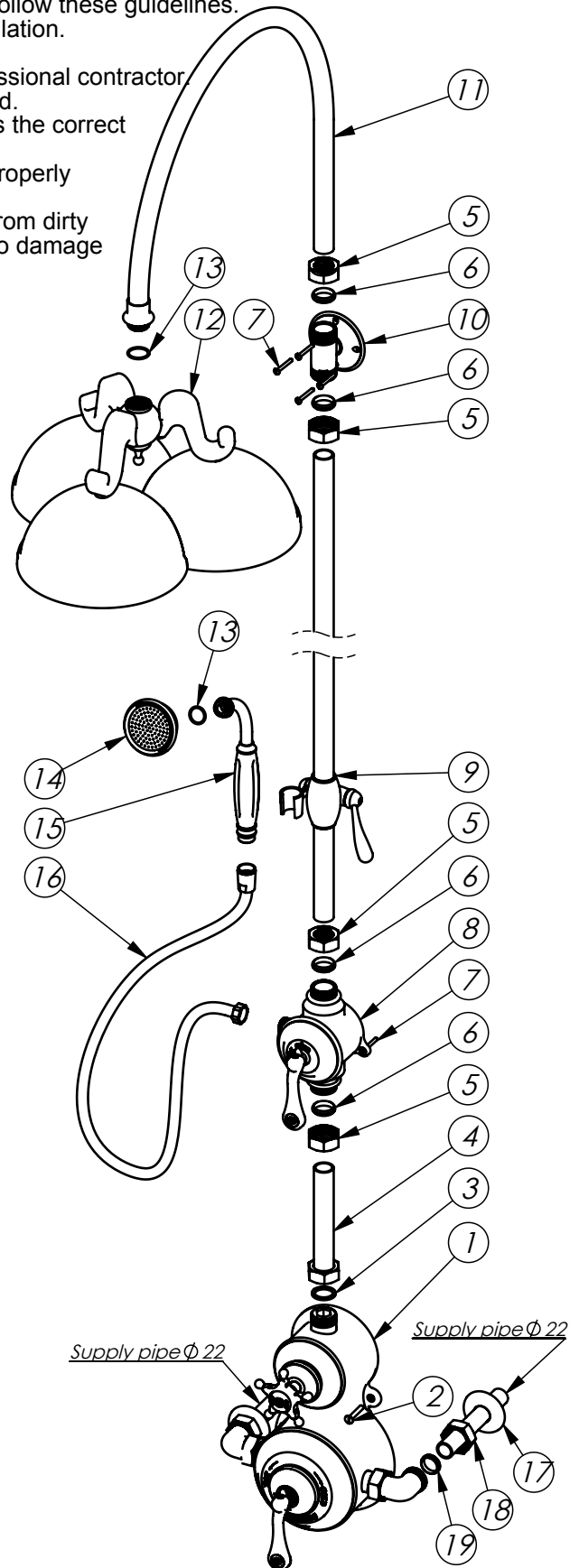

ITEM NO.	NAME	NO OF.
1	Control block	1
2	12x1.1/2" screws	2
3	Fibre washer	1
4	Pipe with a nut	1
5	Compression nut M32/ Ø 25	4
6	Olive Ø25	4
7	8x1.1/2" screws	6
8	Shower diverter	1
9	Pipe with cradle	1
10	Wall plate	1
11	Curved pipe / Straight pipe	1
12	Shamrock rose	1
13	O-Ring	2
14	Shower rose	1
15	Handset	1
16	Shower hose	1
17	Escutcheon	2
18	Compression nut M32/ Ø 22	2
19	Olive Ø 22	2

1. Install the shower block (1) - ensuring correct alignment with the supply - at a suitable height using screws provided through the mounting lugs, do not drill through the lugs as this could cause damage to the plating.
2. Remove the control block from the wall and then the side elbows from the control block. Attach the side elbows to the supply and then install the control block. Connect the side elbows, ensuring that olives are correctly seated. A little clearance between the elbow escutcheon to the wall is beneficial so that when the control block is installed it does not place any strain on the supply pipework. If the control block is stripped in anyway take care not to damage the non return valves.
3. Install pipe (4) into control block (1) with washer (3) and nut on the pipe, do not tighten at this stage. The diverter is to be installed next at a suitable height, trimming pipe (4) as necessary. Position diverter (8) onto pipe (4) with olive (6) and nut (6) do not tighten at this stage, ensure that the diverter is central and vertical to the control block. Fix the diverter to the wall then tighten nut (5) and lower nut on the pipe but do not unduly place strain upon the diverter or control block whilst tightening the nuts ensuring that the olive and washer are correctly seated.
4. Determine the position of the wall plate (10) and cut pipe (9) to length. Position these on the wall ensuring that they are central and vertical to the control block and diverter and that the pipe is seated in the diverter and wall plate, scribe lines through the wall plate for the fixing holes - do not drill through the wall plates as this could damage the plating - then remove from the wall and drill the fixing holes.
5. Install pipe with cradle (9) into diverter (8) with olive (6) and nut (5) do not tighten at this stage. Position wall plate (10) onto pipe (9) with olive (6) and nut (5) do not tighten at this stage. Fix wall plate to the wall then tighten both nuts (5) ensuring both olives are seated correctly but do not unduly place strain upon the wall plate whilst tightening the nuts.
6. Determine length required of the curved/straight pipe (11) cutting to length if necessary. Install into wall plate (10) with olive (6) and compression nut (5), tighten the compression nut ensuring that the pipe (11) is at the correct angle to the wall, taking care not to unduly place strain upon the wall plate.
7. Screw shamrock rose (12) onto pipe (11) making sure that o ring (13) is correctly seated.
8. Connect shower rose (14), handset (15) and shower hose (16) ensuring that the seals are correctly seated.
9. Check all joints are watertight and test the system.

Operating the diverter

Turn the handle to select overhead shower or hand set shower.
Make sure that the hand shower is secure before turning on.

Operating the shower

Use the lower arm to select the desired temperature and the upper handle to open the flow of water to the showerhead.

Notes: Drummond's products are handmade therefore dimensions may vary slightly. Please try to recycle all packaging where possible and leave the item well protected for the customer - thank you. The manufacturer's warranty does not cover any products which have been damaged as a result of misuse, faulty installation or maintenance.

Cleaning

You will need to regularly de-scale your shower heads, we recommend you detach the shower head and use a kettle de-scaling pack on the head. Please take care with the Shamrock head as it is heavy. Brass - use a mild non-abrasive cleaner such as brasso. Chrome and nickel plated products - use a mild non-abrasive cleaner such as silvo.

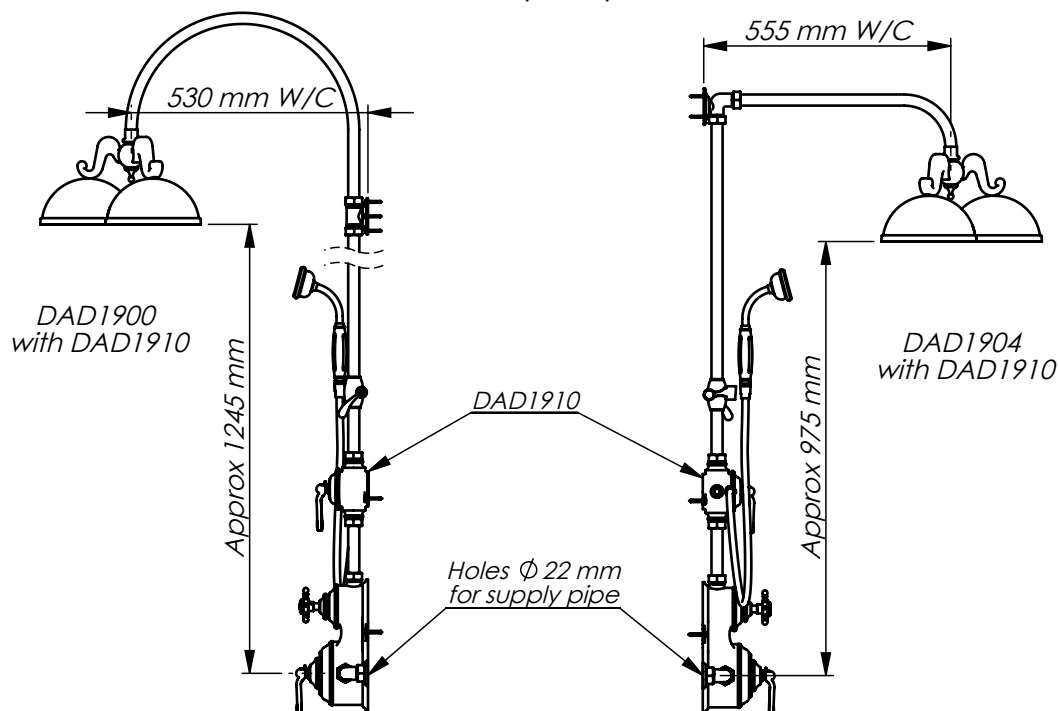

All our goods are handmade and may vary slightly from drawings. If you are unsure of how to assemble the goods, please call us and we will try help over the phone. We would also ask that you try and recycle all packing where possible and leave the item well protected for the customer. Thank you.